

# NWS-20-50-LT-L

## 标签供料器 Label feeder

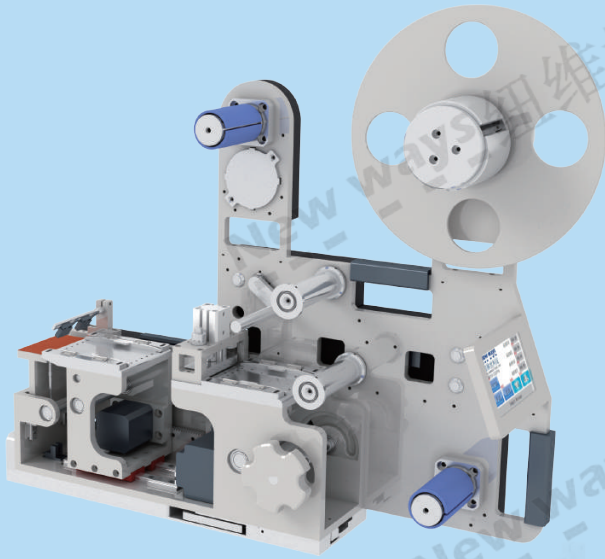

### 操作界面 Operation Interface

- 搭配4.3寸触摸屏，显示简洁。  
Configuring with 4.3 Inch touch-panel, simplified display.
- 工作模式\手动\自动，灵活切换。  
Operating mode: manual\ automatic on flexible switching.
- 参数化设置\送标速度\送标长度。  
Parameterized setting: feeding speed、feeding length.
- 报警提示\无料报警\断料报警。  
Alarm indication: empty alarm、break alarm.

### 关键规格 Key Specs

- 工作电压：24V  
Working voltage: 24V
- 气压：0.4 ~ 0.6Mpa  
Air pressure: 0.4 ~ 0.6Mpa
- 尺寸：567[L] \* 170[W] \* 516[H] mm  
Dimension: 567[L] \* 170[W] \* 516[H] mm
- 适用料带宽度：20 ~ 50mm  
Matl. tape width: 20 ~ 50mm
- 送料精度范围：+/-0.1mm ~ +/-0.2mm  
Feeding precision: +/-0.1mm ~ +/-0.2mm

### 主要特性 Main Features

- 模块化设计，节省空间，维护简单，可快速拆卸，适合搭配各种标准、非标设备使用。  
Modular design, space-saving, simplified maintenance, SMED, various application in standard and non-standard machines.
- 适用于各种标签和泡棉，针对锂电池\手机\电脑\包装等应用。  
Applicable for labels and foam of Li-battery, smart phone, laptop, packaging, etc.
- 多种脱标方式，直接脱标\与机器人配合同步送料脱标\后撤式脱标。  
Multi-de-labeling mode: direct de-labeling, sync-with robot on material feeding and de-labeling, withdraw de-labeling.
- 采用步进电机送料和激光传感器定位，相互弥补物料传送位置不稳定因素，精准控制送料长度，确保每一次送料准确无误。  
Configuring with stepping motor on feeding and laser sensor on positioning to compensate the factor of un-stable material feeding position, precisely control feeding length to be ensure supplying accuracy.
- 换料\收料简单便捷，一键式张紧\放松料带。  
Material change、receiving, simplification, one-tap operation on tensioning or relaxing material tape.
- 最薄支持0.02mm，送料光纤定位最高精度±0.1mm~±0.2mm。  
Feeding tape min. thickness 0.02mm, laser sensor positioning precision +/-0.1mm ~ +/-0.2mm
- 自主独立开发软件，标准化操控界面，简洁实用。  
Independent development on software, standardized operation interface, simplification and adaptability.



简洁外观  
simplified feature

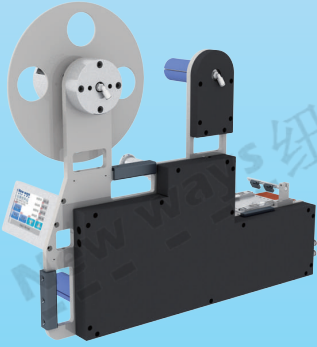

收\放料气胀轴  
receiving、relaxing air shaft

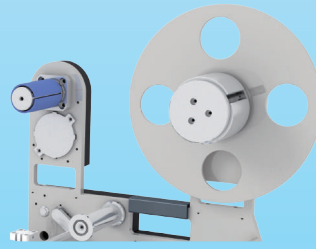

真空辅助  
vacuum assist

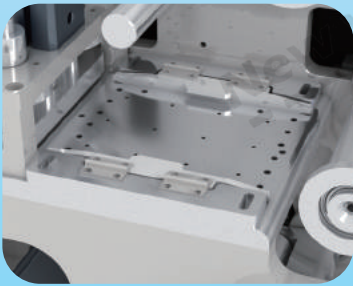

激光感应器定位  
laser sensor positioning

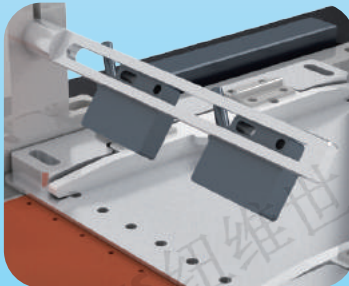

信号串口  
signal com



快速装卸定位卡勾  
SMED hooking



适用物料类型 various materials in application

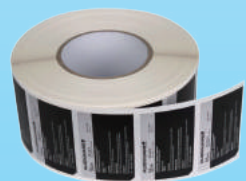

新思路  
打造产品  
新概念  
赢得客户

简洁  
便捷  
高效

## 外形尺寸 Configuration and Dimension

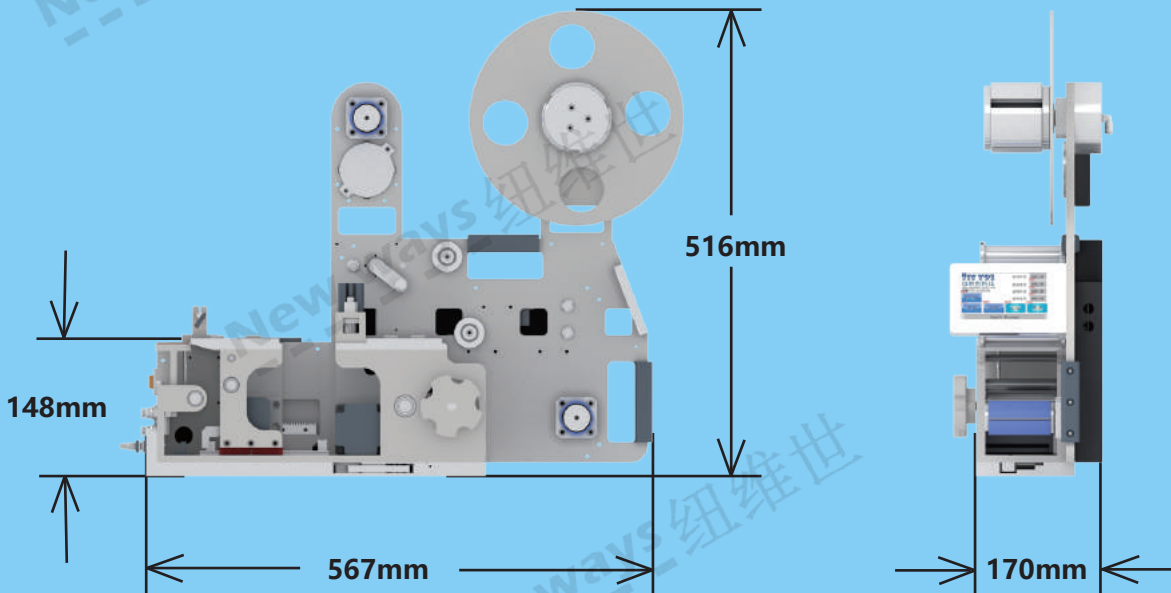

## 详细规格 Detail Specification

项目 Items	参数/说明 Parameters\Description	项目 Items	参数/说明 Parameters\Description
外形尺寸 Config. and Dim.	L 567*W 170*H 516mm	工作电压 Working Voltage	24V
重量 Weight [Kg]	8.5Kg	工作电流 Working Current	0.5A~1.5A
材质 Substance	A6061	气压 Air Pressure	0.4~0.6Mpa
物料底纸厚度 Matl. tape thickness	0.05~0.2mm	触摸屏尺寸 Touch-panel Size	4.3 Inch
物料总厚度 Matl. tape total thickness	<5mm	感应器类型 Sensor Type	激光感应器 Laser Sensor
物料料带宽度 Matl. tape width	20mm~50mm	剥离驱动方式 De-label Driving Mode	精密行星减速步进电机 Precise Stepping Motor
料卷直径 Outside Diameter	定制化 (Customized)	供料精度 Feeding Precision	±0.1mm~±0.2mm
卷料内径 Inner Diameter	φ 75mm	送标速度 Feeding Speed	1~120mm/s
物料承重 Matl. Loading [Kg]	最大3Kg, 或者定制化 Max. 3Kg or Customized	通讯接口 COM	通用端口 General COM
物料应用 Application	锂电池: 防水胶, 外观胶, PSA胶, VHB胶等。 其它: 标签、保护膜、二维码、麦拉、铜箔、补强片、泡棉、导电布、导热硅片等。 Li-battery: water-pooof tape, cosmetic tape, PSA tape, VHB tape, etc. Others: labels, OPP film, QR Code, mylar, copper foil, foam, conductive tape, thermal pad, etc.		



**New ways** 深圳市纽维世科技有限公司  
ShenZhen New Ways Technology Co., Ltd

公司名称：深圳市纽维世科技有限公司

地址：深圳市光明区白花社区第三工业区11号B栋6层

网址：<http://www.newways-tech.com>

电话：0755-23200784

